

AnalogPlus™ Dissolved Ozone Sensor

INSTRUCTION MANUAL



1-Inch NPT Mounting



Instruction Manual



Instruction Manual

Preface

This instruction manual serves to explain the use of the AquaSensors AnalogPlus™ 1.0 inch Dissolved Ozone sensor and is written to cover as many applications as possible. Please do not hesitate to contact AquaSensors or an authorized AquaSensors representative with questions or concerns.

The information presented in this instruction manual is subject to change without notice as improvements are made, and does not represent any commitment whatsoever on the part of AquaSensors.

AquaSensors cannot accept any responsibility for damage or malfunction of the sensor due to improper use.

Contact Information

Mail: AquaSensors, LLC; PO Box 607, Brookfield, Wisconsin 53008-0607

Shipping: AquaSensors LLC; W141N9230 Fountain Blvd, Menomonee Falls, Wisconsin 53051

Phone: 262-255-4459 Between 8:00 AM and 5:00 PM Central Time.

Fax: 262-255-4708

Email: Sales@AquaSensors.com

Web: www.AquaSensors.com

Safety Information



The AquaSensors AnalogPlus 1.0 inch Dissolved Ozone sensor shall be installed and operated only in the manner specified. Only a skilled, trained or authorized person should carry out installation, setup and operation of the sensor system.

Before using the sensor, make sure that the sensor cable is connected as specified. Failure to do so may result in permanent damage to the sensor or controller.

Protection against electric shock will be achieved only by observance of the corresponding installation rules.

TABLE OF CONTENTS

1. INTRODUCTION.....	5
1.1. GENERAL INFORMATION	5
1.2. INTENDED USE	6
2. PRODUCT DESCRIPTION.....	7
2.1. SENSOR DESCRIPTION	7
2.2. SENSOR CARE AND START-UP	8
2.3. SPECIFICATIONS	9
3. INSTALLATION.....	10
3.1. WIRING	10
3.2. SENSOR CONSTRUCTION	11
3.3. FLOW CHAMBER	12
3.4. UNION MOUNTING	14
4. OZONE SENSOR MAINTENANCE	16
4.1. CLEANING THE OZONE SENSOR HEAD	16
4.2. OZONE SENSOR REFURBISHMENT - REPLACING THE MEMBRANE CAP AND ELECTROLYTE	17
4.3. OZONE SENSOR TROUBLESHOOTING	18
5. OZONE PART NUMBERS	19
5.1. OZONE SENSOR, AV88 UNIVERSAL ANALYZER AND MOUNTING HARDWARE OPTIONS	19
5.2. OZONE ELECTROLYTE AND MEMBRANE CAPS	20
6. LIMITED WARRANTY	21
7. TERMS AND CONDITIONS.....	22

1. INTRODUCTION

1.1. General Information

Thank you for purchasing the AquaSensors AnalogPlus™ Dissolved Ozone Sensor. This industrial sensor has many enhanced features that offer superior performance in process applications.

The product is designed for continuous use in industrial process applications and complies with safety regulations currently in force. Improper use could lead to hazards for the user or a third-party, and/or adverse effects to the plant or other equipment.

AquaSensors does not accept any liability for damage that may arise if information in this manual is not followed. Therefore, the operating instructions and specifications must be read and understood by all persons involved in installation and operation of this equipment.

This manual identifies safety instructions and additional information by means of the following symbols:

	This symbol draws attention to safety instructions and warnings of potential danger , which if neglected, could result in injury to persons and/or damage to property.
---	---

	This symbol identifies additional information and instructions , which if neglected, could lead to inefficient operation and possible loss of production.
---	--

It is recommended that this manual be made accessible to everyone who may need it as a reference.

Please contact AquaSensors or an authorized AquaSensors representative with any questions.

1.2. Intended use

AquaSensors' AnalogPlus 1.0 inch Dissolved Ozone sensor is designed to continuously measure Ozone and temperature in aqueous solutions in accordance with the technical product specifications in Section 2.2 of this manual.

Any other use, or use not mentioned here, that is incompatible with the technical specifications is deemed inappropriate. The operator is solely responsible for any damage arising from such use.

Other prerequisites for appropriate use include:

- Observing the instructions, notes and requirements set out in this instruction manual.
- Observing all local safety regulations.
- Observing all warnings and cautions in the documentation regarding all products used in this measurement system, including the Ozone sensor, mounting hardware, analyzer electronics and cabling.
- Observing the prescribed environmental and operational conditions.
- Observing chemical compatibility with all wetted materials.

1.3. Safety Instructions

The AnalogPlus 1.0 inch Dissolved Ozone sensor should be installed and operated only by personnel familiar with the sensor and qualified for such work.

A defective sensor should be returned to AquaSensors for repair or replacement. Contact AquaSensors to obtain a Return Material Authorization (RMA) number.



No modifications to the AnalogPlus 1.0 inch Ozone sensor are allowed. The manufacturer/supplier accepts no responsibility for damage caused by unauthorized modifications. The risk is borne entirely by the user.

1.4. Removal from Service / Correct Disposal of the Sensor

Removal from Service

- Disconnect the cable wiring from the controller terminal block.
- Remove the sensor from the mounting hardware.

Correct Disposal of Unit

- When the sensor is taken out of service, observe the local environmental regulations for correct disposal.

2. PRODUCT DESCRIPTION

2.1. Sensor Description

The AquaSensors 1.0 inch Dissolved Ozone sensor uses the amperometric measurement technique to maximize lifetime in continuous industrial applications. The sensor is easily maintained and reconditioned by replacing the convenient membrane cap and electrolyte. The wires in the sensor cable are color coded to allow for quick and easy installation into the AV88 Universal Analyzer.



Figure 2.1: 1.0 inch Ozone Sensor

The wires in the sensor cable are color coded to match the terminal strip connection within the AV88 Universal Analyzer Controller.

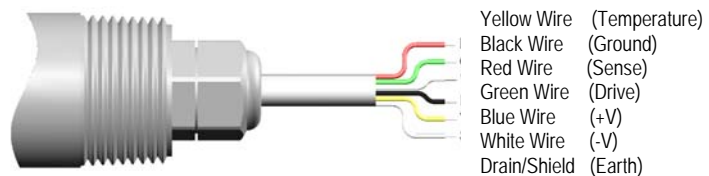

Figure 2.2: Ozone sensor hook-up

The sensor body has 1 inch NPT threads for the following mounting options:

- Pipe tee assembly
- Immersion mount assembly
- Union mount assembly

2.2. Sensor Care and Start-up

Working with the Protective Cap

The sensor is shipped with a protective cap on the sensor head to keep the membrane wet and to protect the membrane from damage. The cap should remain on the sensor head until the sensor is installed in liquid process. It is important to note that the cap should be pulled straight off by inserting a fingernail between the cap and the sensor body and walking the cap down until it comes off. Be careful not to touch the membrane.

Working with the Membrane Cap

The ozone membrane cap has a metal cover that protects the FEP measurement membrane. This is an integral part of the sensor cap. The cap is screwed on and care should be taken not to unscrew it. The cap contains ozone electrolyte that will spill out if the cap is removed.

Power the Sensor Prior to Calibration

The sensor has been charged and tested prior to shipment. After installation, leave the sensor powered for at least 12 hours in the process prior to calibration. The AV88 analyzer supports 1-point sample calibration.

The **1-point sample calibration** should be done with a measured ozone reading that is as high up the scale as possible. With this calibration the current sensor reading can be set to a known value.

Temperature can also be calibrated with a sample calibration and it may be advantageous to calibrate the temperature of the sensor prior to calibration of ozone since the ozone reading is compensated by temperature.

Take care to protect the sensor membrane from impact and be sure to keep the membrane cap tight.

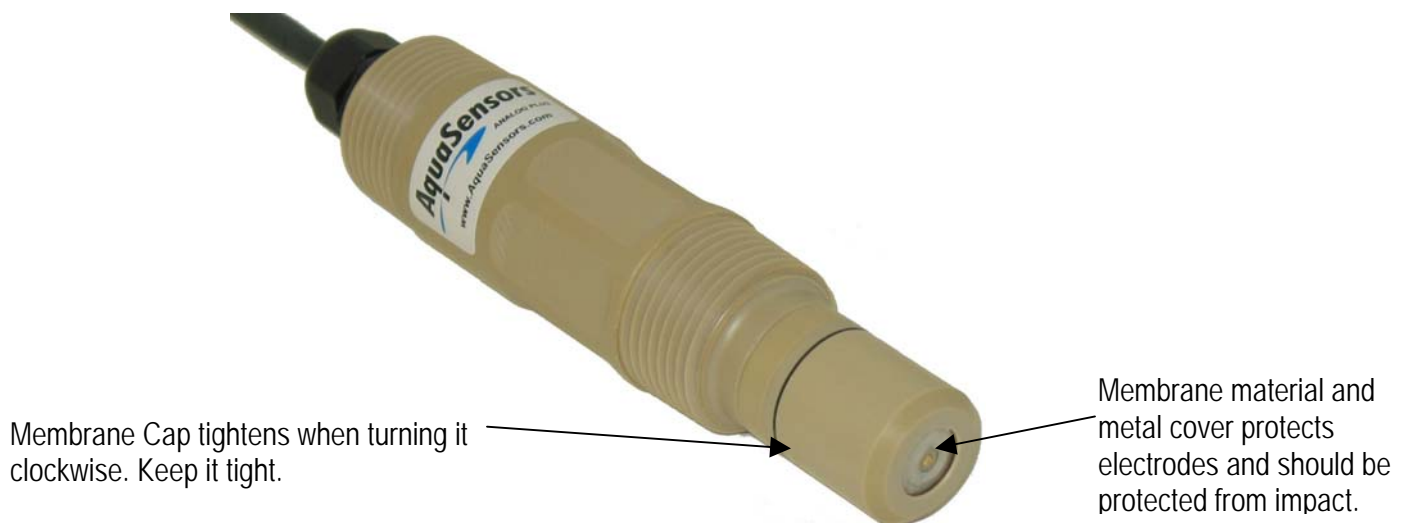

2.3. Specifications

Wetted Materials.....	Sensor Body – PEEK® Membrane – FEP O-Ring Seals - Viton®
Operating Temperature.....	23°F to 122°F (-5°C to 50°C)
Maximum Pressure.....	100 psi @ 50°F
Max Operating Pressure.....	20 psi @ 50°F
Maximum Flow Rate.....	10 ft/sec (3 m/sec)
Dissolved Ozone Measuring Range.....	0 to 10 ppm
Resolution.....	0.01 ppm
Standard Sensor Cable Length.....	10 ft (3 m)
Cable Wire Colors.....	Yellow Wire (Temperature) Black Wire (Ground) Red Wire (Sense) Green Wire (Drive) Blue Wire (+V) White Wire (-V) Drain/Shield (Earth)
Maximum Transmission Distance.....	300 ft (914 m)

	<p>The sensor will arrive with a protective cap that keeps the sensor membrane hydrated.</p> <p>For short-term storage, put several drops of AquaSensors Ozone electrolyte on the absorbent material in the protective cap and replace the cap on the sensor. This keeps the membrane moist.</p> <p>For extended storage, repeat the above short-term storage procedure every 2 to 4 weeks, depending on the surrounding environmental conditions.</p>
---	--

	<p>Make sure all wetted materials are compatible with process chemicals at operating temperatures and pressures.</p>
---	--

3. INSTALLATION

3.1. Wiring

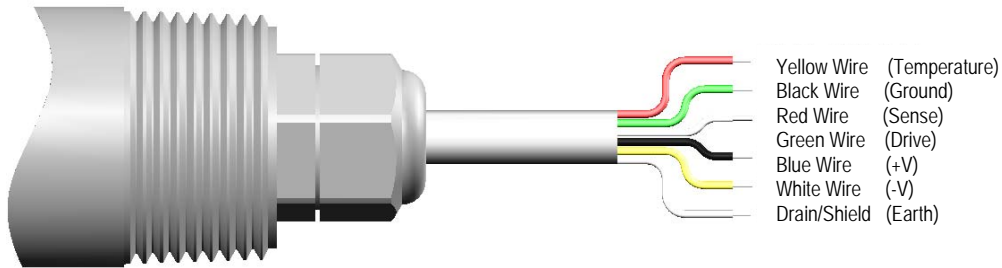

Figure 3.1: Ozone Sensor Hook-Up

There are two different methods for electrical connection between the sensor and the Ozone Analyzer - either direct or through a junction box.

3.1.1. Direct Connection

1. Insert the sensor cable through a watertight cord grip into the AV88 Universal Analyzer. Conduit holes are found on the bottom of the analyzer for this purpose.
2. Connect the sensor wires to the AV88 as shown on the AV88 wiring chart.

3.1.2. Indirect Connection (Using a Junction Box)

1. Insert the sensor cable and the interconnect cable through a watertight cord grip into the junction box that has a terminal strip designed to make the proper connections.
2. Connect both the sensor cable wires and the interconnect wires to the terminal strip.
3. Insert the interconnect cable through a watertight cord grip into the AV88G Analyzer. Conduit holes are found on the bottom of the analyzer for this purpose.
4. Connect the sensor wires to the AV88 as outlined in the analyzer manual.



Be sure that the wire colors of the sensor cable match those of the interconnect cable on either side of the terminal strip.



Route the interconnect cable through metal conduit to minimize electrical noise that may interfere with the sensor signal.

3.2. Sensor Construction

The AnalogPlus Ozone sensor has 1-inch NPT threads on the front and back of the sensor body for easy installation in tee and union mount hardware.

	Save the protective cap and use it to keep membrane moist whenever the sensor is removed from service.
--	--

	If the sensor does not calibrate, refer to Section 4 to review maintenance, refurbishment and troubleshooting options.
--	--

	The sensor should be positioned at least 15° up from horizontal. This will insure that entrained air does not form a pocket around the sensor head.
--	---

	DO NOT USE PIPE SEALANT. Pipe sealants may not provide adequate sealing or may react with different plastic materials. Use thread tape.
--	--

	DO NOT OVER TIGHTEN! Maximum torque: 65 lbs·inch (7 N·m)
--	---

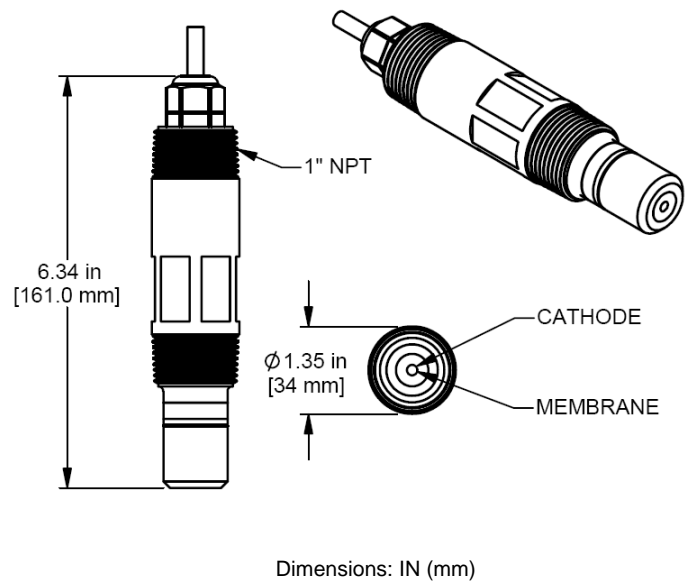

Dimensions: IN (mm)
Figure 3.2: 1 Inch Sensor Body

3.3. Flow Chamber

The flow chamber is used in a bypass configuration with the inlet process water connected to the bottom of the chamber with ridged or semi-ridged ¼ inch tubing. The flow chamber valves are stainless steel press fittings. A shutoff valve and a flow regulator are recommended to keep flow and pressure constant at the sensor head. The outlet is usually routed to drain. It is recommended that the end of the drain hose be inserted into the drainpipe to reduce the chance of ozone dissipating in the air.

For this mounting option the sensor must be ordered with a membrane cap with a face seal (Part Number: DMR04-Z). To install the sensor, unscrew the retaining ring (counter clockwise) and insert the sensor so that the face seal rests inside the chamber. Run the sensor cable through the retaining ring and thread the retaining ring down until hand tight. After the sensor is installed, turn on the water and be sure there are no leaks past the retaining ring or the inlet / outlet fittings.

Allow the sensor to run for 12 hours before calibration.

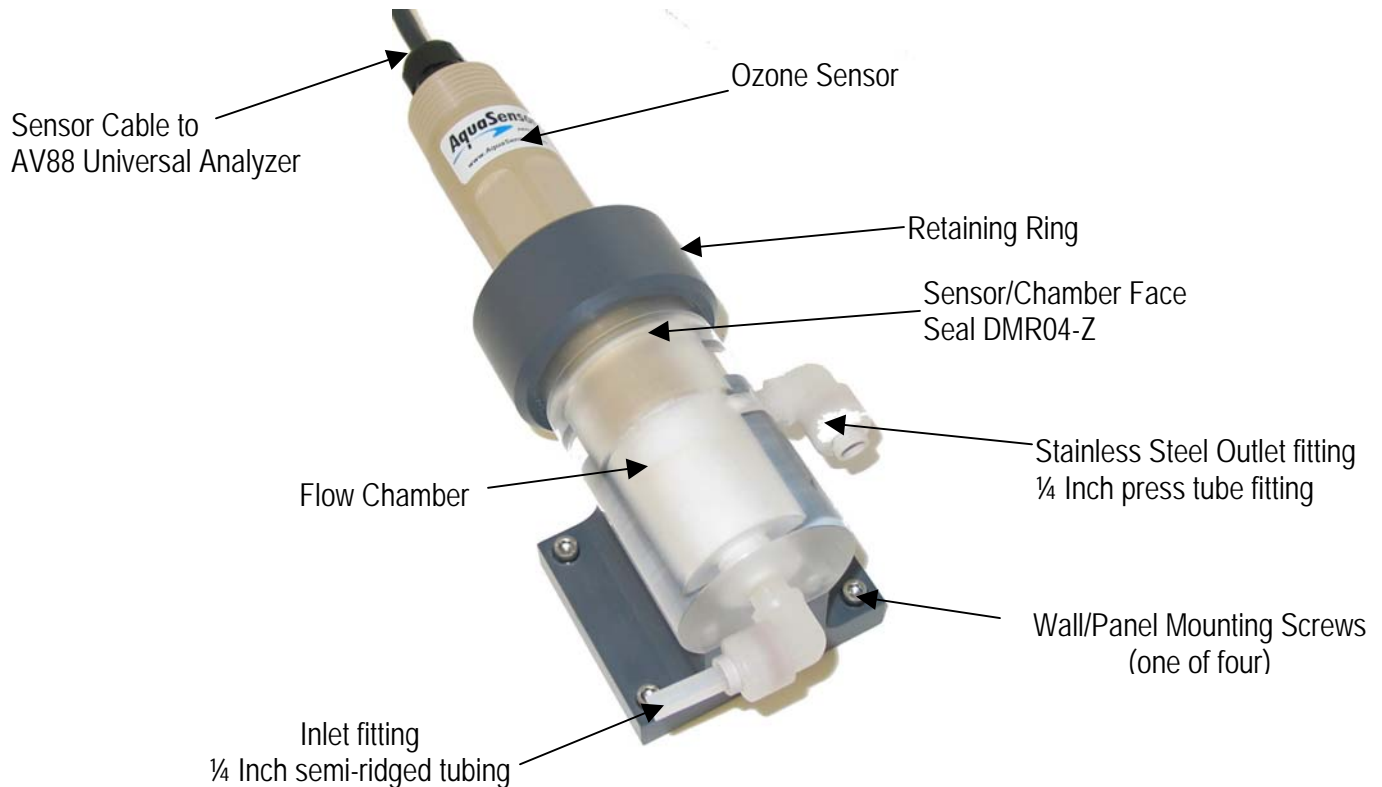

Figure 3.3: Flow Chamber

Detailed Flow Chamber Installation Instructions

1. Wiring:
 - a. Route the cable either through conduit or on a cable tray.
 - b. Insert the sensor cable into the AV88 Universal Analyzer through a watertight cord grip. Conduit holes are provided for the cord grip on the bottom of the AV88 Universal Analyzer.
 - c. Connect the sensor wires into the AV88 sensor terminal block as shown in the AV88 manual.

2. Calibrate:
 - a. Power the AV88 Analyzer and let the sensor run for at least 12 hours before calibration.
 - b. Remove the protective cap from the sensor head and make sure moisture is present and the membrane has not dried out. If the protective cap is dry, the sensor should be hydrated in tap water for at least 12 hour prior to calibration.
 - c. Calibrate the ozone sensor as explained in the AV88 manual. Subsequent calibrations should be scheduled based on process demands.

3. Mount:
 - a. Insert the ozone sensor with face seal into the chamber.
 - b. Secure the sensor with the retaining ring.

3.4. Union Mounting

Union mount hardware makes it easy to remove and insert the sensor for applications where calibration and/or cleaning is frequent. In pipe installations a 'Y' configuration is recommended to reduce the impact of particulate matter on the sensor head and improve sensor life. Union Mounting in a 'T' configuration is also available.

Union Mount Advantages

- ✓ Optimal positioning of sensing surface.
- ✓ Trouble-free installation.
- ✓ Quick disconnect.
- ✓ No cable twisting during installation or removal.
- ✓ Easy maintenance.

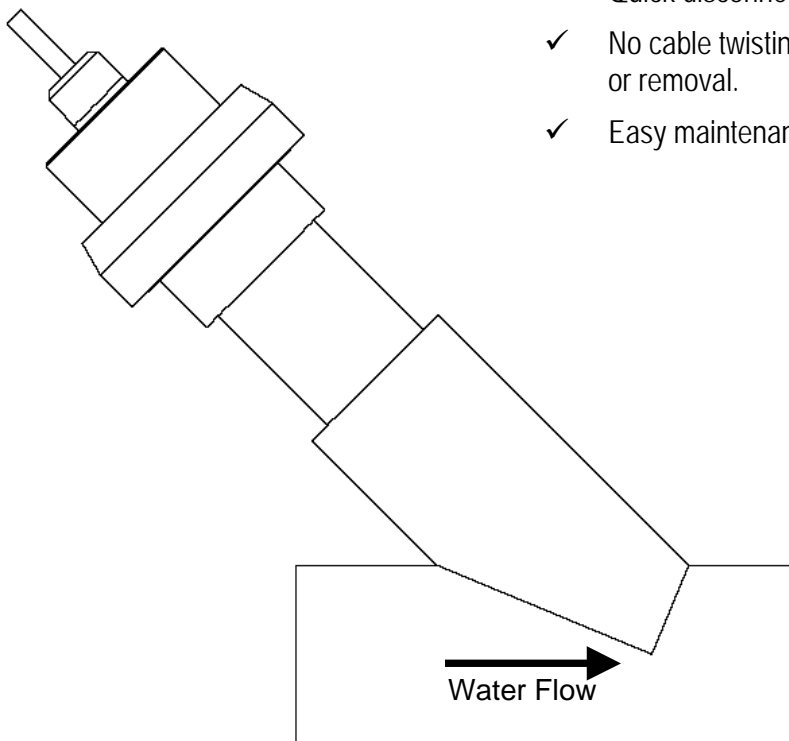

Union Hardware in Y Configuration to reduce wear on sensor head.
Part Number: MH1042-Y

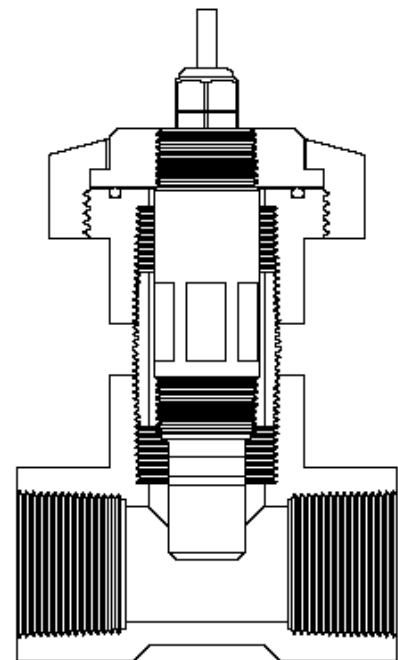

Union Hardware in T Configuration. :
Part Number: MH1042
Dimensions: IN (mm)

Figure 3.4: Union Mounting Options

Detailed Union Mount Installation Instructions

1. Wiring:
 - a. Apply Teflon® tape to the rear sensor body threads and pass the cable through the adapter. Thread the adapter onto the sensor clockwise until it is secure.
 - b. Pass the union collar over the cable and onto the adapter with the threads facing the sensor.
 - c. Route the cable either through conduit or on a cable tray.
 - d. Insert the sensor cable into the AV88 through a watertight cord grip. Conduit holes are provided for the cord grip on the bottom of the AV88 Analyzer.
 - e. Connect the sensor wires into the AV88 sensor terminal block as shown in the AV88 manual.

2. Calibrate:
 - a. Power the AV88 Analyzer and let the sensor run for at least 12 hours before calibration.
 - b. Remove the protective cap from the sensor head without twisting and make sure moisture is present and the membrane has not dried out. If the protective cap is dry, the sensor should be hydrated in tap water for at least 12 hour prior to calibration.
 - c. Calibrate the Dissolved Ozone sensor as explained in the AV88 manual. Subsequent calibrations should be scheduled based on process demands.
 - d. If measurement response time is slow or if the sensor will not calibrate, refer to Section 4 for maintenance, refurbishment and troubleshooting suggestions.

3. Mount:
 - a. Assemble the lower portion of the mounting hardware by threading the pipe nipple into the threaded flange and the tee. Apply Teflon® tape to the threads.
 - b. Inspect the O-ring on the union-mounting threaded flange for imperfections or particles of dirt that may prevent the O-ring seal from seating properly.
 - c. Carefully insert the sensor into the AquaSensors union-mounting tee. Turning the retaining collar clockwise and hand tighten until snug. Be sure the pipe remains full when the sensor is installed.

4. Ozone Sensor Maintenance

4.1. Cleaning the Ozone Sensor Head

- 4.1.1. In order to maintain an accurate measurement value, the sensor will need occasional maintenance. The maintenance interval will be dictated by the process in which it is installed. The harsher the process, the more often the sensor will require maintenance. Regular maintenance will yield a longer sensor life.
- 4.1.2. The sensor cleaning procedure is as follows:
 - 4.1.2.1. Remove sensor from service and rinse or spray it with warm water to remove heavy deposits.
 - 4.1.2.2. Soak the sensor in a container of warm detergent water for one hour. Do not use detergents that contain oily skin softeners like aloe or lanolin that can coat the membrane. Alconox® and Dawn™ dishwashing liquid work well.
 - 4.1.2.3. Rinse the membrane end with clean warm water.
 - 4.1.2.4. If deposits are still present on the membrane repeat soaking and rinsing steps.
- 4.1.3. Before returning the sensor to service, allow it to soak in water at ambient temperature for about an hour to stabilize the Dissolved Ozone membrane.
- 4.1.4. After cleaning the sensor, calibrate sensor per instructions in the AV88 Analyzer manual.
- 4.1.5. Reinstall sensor in process.

4.2. Ozone Sensor Refurbishment - Replacing the Membrane Cap and Electrolyte

4.2.1. If the sensor head has been cleaned (see section 4.1.2) and calibration cannot be achieved, replace the membrane cap and electrolyte solution.

4.2.2. Hold the sensor firmly with the electrode tip facing down. Remove the existing membrane cap by turning it counterclockwise. Dispose of the old membrane cap and electrolyte using an approved method.

4.2.3. Slowly fill the new membrane cap with ozone electrolyte and gently agitate to remove trapped bubbles.

4.2.4. Place the sensor head into the filled membrane cap.



Install slowly. Screwing on the new membrane cap quickly may cause pressurization of the membrane.

4.2.5. Slowly screw the new filled membrane cap clockwise onto the sensor head until secure. Excess electrolyte will be expelled.



Do not over tighten.
Maximum torque: 10 lbs·in (1.13 N·m)

4.2.6. After replacing the membrane cap and electrolyte, allow the system to run in process for 1 hour before calibration (assuming the sensor has been in service). If a new membrane is installed on a sensor that has not been in service, then wait 12 hours before calibration.

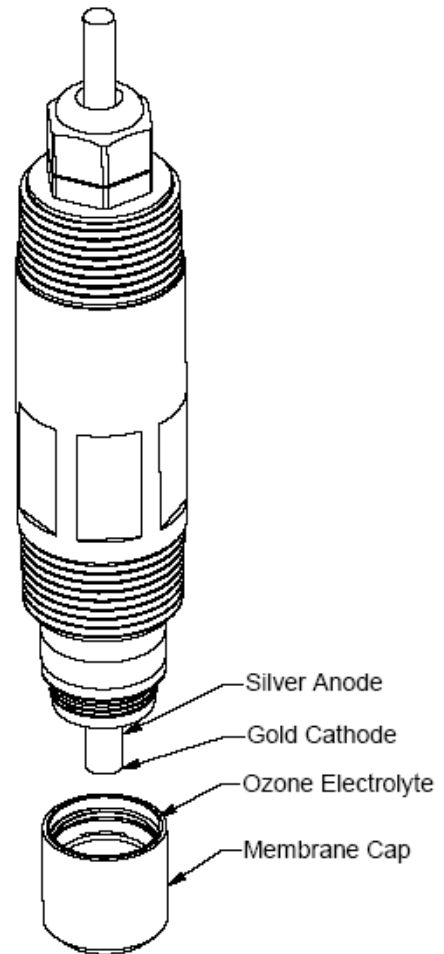

Figure 3.5: Membrane Cap Removed

4.3. Ozone Sensor Troubleshooting

General Inspection

If the sensor is not providing reasonable signals to the analyzer, check the following:

1. Inspect the integrity of the membrane. If the membrane is torn or punctured, replace it a new membrane cap and fresh electrolyte (see section 4.2).
2. Inspect the sensor cable for damage to the outer jacket. Any cuts or kinks may damage signal connections.
3. Inspect terminal block connections to be sure wires are not corroded or loose.
4. Make sure all sensor wires are connected to the correct places on the analyzer terminal block. Depending on the analyzer.
5. The sensor should be immersed in a solution of known ozone concentration.
6. Establish that the analyzer electronics are working correctly by verifying operation with another sensor.



Note: Any new sensor that has been in storage for more than a few days should be soaked in tap water with power applied for at least 12 hours before reviewing measurement performance.



Note: The membrane of any Dissolved Ozone sensor in storage must be kept moist at all times. Protective caps should be filled with AquaSensors storage solution for best performance. The protective cap should be placed securely over the sensor head.

5. Ozone Part Numbers

5.1. Ozone Sensor, AV88 Universal Analyzer and Mounting Hardware Options

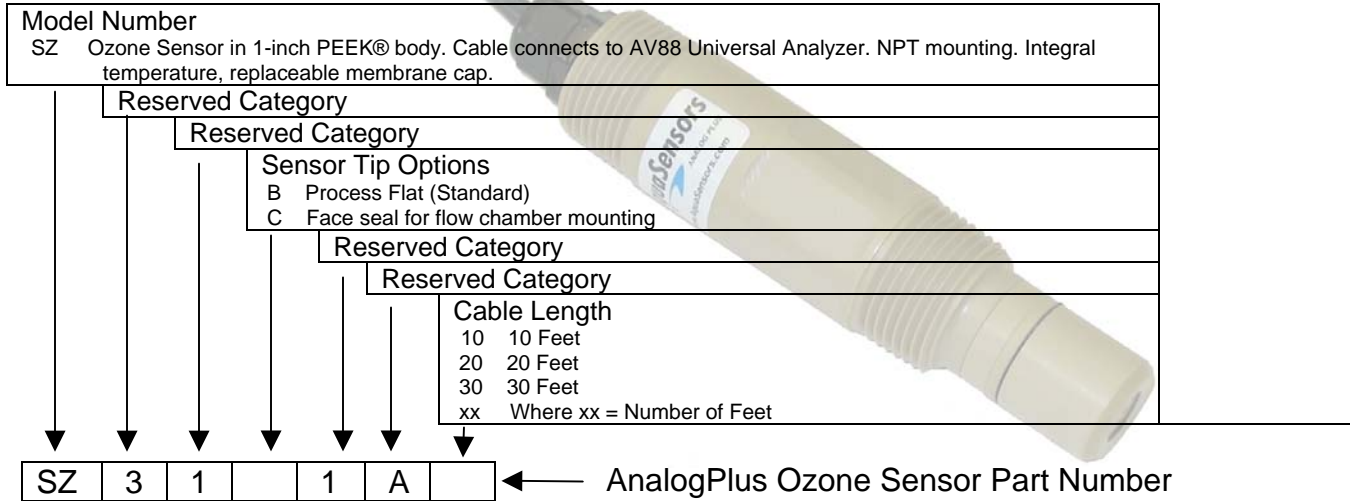

Part Number Suffixes for Special Body Construction	
-IN15	1.5-inch Ball Valve Insertion Mount (No front threads)
-S15	Sanitary Style 1.5" Triclamp.
-S20	Sanitary Style 2.0" Triclamp.

Analyzers	Description	Part Number
AV88 Universal Analyzer	2 outputs, 2 relays, AC power. ¼ DIN.	AV88GB0C2
	2 outputs, Modbus Host Comms. 24VDC. ¼ DIN.	AV88GB4A1
	2 outputs, 2 relays, 24VDC. ¼ DIN	AV88GB0C1
	2 outputs, 24VDC. ¼ DIN	AV88GB0A1

Mounting Hardware	Description	Part Number
Flow Chamber	Acrylic Flow chamber with mounting plate and stainless steel fittings.	FC002
1.5" Union 'T' construction	Stainless Steel	MH3041
1.5" Union 'Y' construction	Stainless Steel	MH3041-Y
1" Tee	Schedule 40, Stainless Steel with insert	MH3011
1.5" Ball Valve	Low Pressure, Stainless Steel High Pressure, Stainless Steel	MH1111 MH1121
2" Tri-Clamp Assembly	2" Tri-Clamp tee, gasket and clamp, Stainless Steel	MH1261 -T
Junction box	For extension cables. Terminal strip included.	JBOX01
Extension Cable	AnalogPlus Extension cable	APECxx; xxx=ft

5.2. Ozone Electrolyte and Membrane Caps

Product	Description	Part Number
Ozone Electrolyte	Electrolyte in the ppm range. – 60ml bottle	RDOK2
Membrane Cap Flat	Process Flat for Ozone	DMRO8-Z
Membrane Cap Face Seal	Flat cap for o-ring with pre-stretched membrane	DMR04-Z
Protective Cap	To keep stored membrane wet when stored.	SBC01

6. Limited Warranty

AnalogPlus™ Ozone SENSOR WARRANTY/REPLACEMENT PLAN

AquaSensors, LLC warrants its AnalogPlus™ 1.0 Inch Ozone sensors against material and workmanship defect for a period of one year from the date of shipment in accordance with the following prorated schedule:

In the event that a defect is discovered during the warranty period, AquaSensors, LLC agrees, at its option, to repair or replace the defective product according to the proration schedule listed in this limited warranty. Any product repaired or replaced under this warranty will be warranted only for the remainder of the original product warranty period.

This warranty does not apply to consumable products associated with this product including, but not limited to, chemical reagents and salt bridges.

Products may not be returned without authorization from AquaSensors, LLC. To obtain authorization, please call AquaSensors, LLC for a return material authorization number.

Limitations:

This warranty does not cover:

1. Damage caused by misuse, neglect (lack of appropriate maintenance), alteration, accident or improper application or installation.
2. Damage caused by any repair or attempted repair not authorized by AquaSensors, LLC.
3. Any product not used in accordance with the instructions furnished by AquaSensors, LLC.
4. Damage caused by acts of God, natural disaster, acts of war (declared or undeclared), acts of terrorism, work actions, or acts of any governmental jurisdiction.
5. Freight charges to return merchandise to AquaSensors, LLC.
6. Travel fees associated with on-site warranty repair.

This warranty is the sole expressed warranty made by AquaSensors, LLC in connection with its products. All other warranties, whether expressed or implied, including without limitation, the warranties of merchantability and fitness for a particular purpose, are expressly disclaimed.

AquaSensors' liability shall be limited to the cost of the item giving rise to the claim. In no event shall AquaSensors be liable for incidental or consequential damages.

This warranty is the sole and complete warranty for AquaSensors, LLC. No person is authorized to make any warranties or representations on behalf of AquaSensors, LLC.

AquaSensors, LLC reserves the right to change or modify this warranty at any time.

Control Number: W1003 Rev: 02/08

7. Terms and Conditions

Terms and Conditions of Sale

The following terms and conditions will be presumed acceptable unless changes are made in writing and accepted by both parties in a reasonable amount of time.

Any standard or boilerplate terms and conditions supplied with a written purchase order will not be applicable unless accepted in writing by both parties.

Quotations: All quotations shall be in writing. Written quotations shall be valid for 30 days from the date issued. Verbal quotations or price lists are not valid.

Pricing: All pricing is in **US Dollars**. AquaSensors reserves the right to change pricing without notice.

Terms: Payment terms are **net 30 days** from the date of invoice with approved credit. AquaSensors reserves the right to deny credit or revoke previously extended credit. Past due accounts are subject to interest charges. Other acceptable payment terms are cash, certified check, money order, credit card or letter of credit confirmed by any United States of America bank. Other payment terms are not valid unless accepted in writing.

Sales taxes shall be included on the invoice unless a valid tax exemption certificate is supplied.

Return Material Authorization: Contact AquaSensors Customer Service for a Return Material Authorization (RMA) number. Items returned without an RMA number will be rejected.

All returned merchandise must be in unused, resalable condition, and must not be contaminated with hazardous materials.

Cancelled orders must be returned within 30 days of the date on the invoice and shall be subject to expenses incurred that may include, but are not limited to, inspection and restocking fees. Items returned within 60 days shall be subject to a restocking charge that is equal to 15% of the purchase price. Items returned after more than 60 days shall be subject to a restocking charge equal to 25% of the purchase price. AquaSensors reserves the right to reject any return that is not under warranty after 60 days. Non-stock items are normally not returnable.

Transportation: Orders are shipped FOB AquaSensors, LLC, or factory, by the most efficient means available. Appropriate charges, such as freight and insurance will be added to invoices. All shipments will be insured. Goods damaged in shipment must be reported by the recipient to the freight carrier for claims.

Control Number: TC1001 Rev: 02/08