

Ozone Monitor

2B *Technologies, Inc.*

OPERATION MANUAL

Models 106-H

© Copyright 2010, 2B Technologies, Inc.
All rights reserved.

TABLE OF CONTENTS

<i>IDENTIFICATION RECORDS</i>	iii
<i>PRINTING HISTORY</i>	iv
<i>WARRANTY STATEMENT</i>	v
<i>WARNINGS</i>	vi
<i>OZONE MONITOR INTRODUCTION</i>	1
<i>SPECIFICATIONS</i>	4
<i>OPERATION</i>	5
<i>MENU</i>	8
<i>MAINTENANCE/TROUBLESHOOTING</i>	19
<i>CALIBRATION</i>	22
<i>LABELLED PARTS</i>	25
<i>PARTS LIST</i>	27
<i>SERVICE LOG</i>	28
<i>APPENDIX A: USB INSTALLATION</i>	30
<i>APPENDIX B: USING THE USB CONNECTION</i>	33

IDENTIFICATION RECORDS

Record the following information for future reference:

Unit serial number: _____

Warranty start date: _____
(date of receipt)

PRINTING HISTORY

New editions are complete revisions of the manual and incorporate all previous update pages and write-in instructions. This manual will be revised as necessary. Revisions can be in the form of new editions, update pages, or write-in instructions.

Revision A..... April 2010
Revision B..... September 2010

TRADEMARKS & PATENTS

2B Technologies™, 2B Tech™, 2B™ and Ozone Monitor™ are trademarks of 2B Technologies, Inc.

CONFIDENTIALITY

The information contained in this manual may be confidential and proprietary, and is the property of 2B Technologies, Inc. Information disclosed herein shall not be used to manufacture, construct, or otherwise reproduce the goods disclosed herein. The information disclosed herein shall not be disclosed to others or made public in any manner without the expressed written consent of 2B Technologies, Inc.

© Copyright 2010, 2B Technologies, Inc.
All rights reserved.

WARRANTY STATEMENT

2B Technologies, Inc. warrants its products against defects in materials and workmanship. 2B Technologies will, at its option, repair or replace products which prove to be defective. The warranty set forth is exclusive and no other warranty, whether written or oral, is expressed or implied. 2B Technologies specifically disclaims the implied warranties of merchantability and fitness for a particular purpose.

Warranty Periods

The warranty period is one (1) year from date of receipt by the purchaser, but in no event more than thirteen (13) months from original invoice date from 2B Technologies, Inc.

Warranty Service

Warranty Service is provided to customers via web ticket, email and phone support, Monday - Friday, from 9:00 a.m. to 5:00 p.m., Mountain Time USA. The preferred method of contacting us is through our web ticketing software at:

www.twobtech.com/techsupport

This way all technical staff at 2B Tech will be alerted of your problem and be able to respond. When you receive an email reply, please click on the Ticket link provided to continue to communicate with us directly over the internet. The web ticket approach to customer service allows us to better track your problem and be certain that you get a timely response. We at 2B Tech pride ourselves on the excellent customer service we provide.

You may also contact us by email at techsupport@twobtech.com or by phone at +1(303)273-0559. In either case, a web ticket will be created, and future communications with you will be through that ticket.

Initial support involves trouble-shooting and determination of parts to be shipped from 2B Technologies to the customer in order to return the product to operation within stated specifications. If such support is not efficient and effective, the product may be returned to 2B Technologies for repair or replacement. Prior to returning the product, a Repair Authorization Number (RA) must be obtained from the 2B Technologies Service Department. We will provide you with a simple Repair Authorization Form to fill out to return with the instrument.

Shipping

2B Technologies will pay freight charges for replacement or repaired products shipped to the customer site. Customers shall pay freight charges for all products returning to 2B Technologies.

Conditions

The foregoing warranty shall not apply to defects resulting from improper or inadequate maintenance, adjustment, calibration or operation by customer. Maintenance, adjustment, calibration or operation must be performed in accordance with instructions stated in the Ozone Monitor manual. Usage of maintenance materials purchased from suppliers other than 2B Technologies will void this warranty.

Limitation of Remedies and Liability

The remedies provided herein are the Customer's sole and exclusive remedies. In no event shall 2B Technologies be liable for direct, indirect, special, incidental or consequential damages (including loss of profits) whether based on contract, tort or any other legal theory. The Ozone Monitor manual is believed to be accurate at the time of publication and no responsibility is taken for any errors that may be present. In no event shall 2B Technologies be liable for incidental or consequential damages in connection with or arising from the use of the Ozone Monitor manual and its accompanying related materials. Warranty is valid only for the country designated on the 2B Technologies quote or invoice.

Warnings

ENGLISH



WARNING:
Any operation requiring access to the inside of the equipment, could result in injury. To avoid potentially dangerous shock, disconnect from power supply before opening the equipment.

WARNING:

This symbol, , on the instrument indicates that the user should refer to the manual for operating instructions.

WARNING:

If this instrument is used in a manner not specified by 2B Technologies, Inc. USA, the protection provided by the instrument may be impaired.

ESPAÑOL



ATENCIÓN:
Cualquier operación que requiera acceso al interior del equipo, puede causar una lesión. Para evitar peligros potenciales, desconectarlo de la alimentación a red antes de abrir el equipo.

ATENCIÓN:

Este símbolo, , en el instrumento indica que el usuario debería referirse al manual para instrucciones de funcionamiento.

ATENCIÓN:

Si este instrumento se usa de una forma no especificada por 2B Technologies, Inc., USA, puede desactivarse la protección suministrada por el instrumento.

FRANÇAIS



ATTENTION:
Chaque opération à l'intérieur de l'appareil, peut causer du préjudice. Afin d'éviter un shock qui pourrait être dangereux, déconnectez l'appareil du réseau avant de l'ouvrir.

ATTENTION:

Le symbol, , indique que l'utilisateur doit consulter le manuel d'instructions.

ATTENTION:

Si l'instrument n'est pas utilisé suivant les instructions de 2B Technologies, Inc., USA, les dispositions de sécurité de l'appareil ne sont plus valables.

DEUTSCH



WARNHINWEIS:
Vor dem Öffnen des Gerätes Netzstecker ziehen!

WARNHINWEIS:

Dieses, , auf dem Gerät weist darauf hin, daß der Anwender zuerst das entsprechende Kapitel in der Bedienungsanleitung lesen sollte.

WARNHINWEIS:

Wenn das Gerät nicht wie durch die Firma 2B Technologies, Inc., USA, vorgeschrieben und im Handbuch beschrieben betrieben wird, können die im Gerät eingebauten Schutzvorrichtungen beeinträchtigt werden.

ITALIANO



ATTENZIONE:
Qualsiasi intervento debba essere effettuato sullo strumento può essere potenzialmente pericoloso a causa della corrente elettrica. Il cavo di alimentazione deve essere staccato dallo strumento prima della sua apertura.

ATTENZIONE:

Il simbolo, , sullo strumento avverte l'utilizzatore di consultare il Manuale di Istruzioni alla sezione specifica.

ATTENZIONE:

Se questo strumento viene utilizzato in maniera non conforme alle specifiche di 2B Technologies, Inc. USA, le protezioni di cui esso è dotato potrebbero essere alterate.

DUTCH



OPGELET:
Iedere handeling binnenin het toestel kan beschadiging veroorzaken. Om iedere mogelijk gevaarlijke shock te vermijden moet de aansluiting met het net verbroken worden, vóór het openen van het toestel.

OPGELET:

Het symbool, , geeft aan dat de gebruiker de instructies in de handleiding moet raadplegen.

OPGELET:

Indien het toestel niet gebruikt wordt volgens de richtlijnen van 2B Technologies, Inc., USA gelden de veiligheidsvoorzieningen niet meer.

1. OZONE MONITOR INTRODUCTION

The 2B Technologies Model 106-H Ozone Monitor is designed to enable accurate measurements of ozone over a wide dynamic range extending from 0.01 percent by weight in oxygen (Wt.% O₂) to an upper limit of 20 Wt.% O₂ based on the well established technique of absorption of ultraviolet light at 254 nm. The Ozone Monitor is light weight (4.5 lb, 2.0 kg) and has low power consumption (≈3.6 watt) relative to conventional instruments and is well suited for applications such as:

- Monitoring of ozone generator output
- Monitoring of residual ozone after a cleaning or oxidation process
- Control of industrial ozone processes

Theory of Operation

Absorption of UV light has long been used for measurements of ozone with high precision and accuracy. The ozone molecule has an absorption maximum at 254 nm, coincident with the principal emission wavelength of a low-pressure mercury lamp. Fortunately, few molecules found in ozone process streams absorb at this wavelength.

Figure 1 is a schematic diagram of the Ozone Monitor. Ozone is measured based on the attenuation of light passing through a 0.1 cm absorption cell fitted with quartz windows. A low-pressure mercury lamp is located on one side of the absorption cell, and a sample photodiode is located on the opposite side of the absorption cell. The photodiode has a built-in interference filter centered on 254 nm, the principal wavelength of light emitted by the mercury lamp. A beamsplitter and reference photodiode are used to monitor the lamp intensity without the sample in the beam path. The intensity of light is measured from the reference photodiode (I_0) and from the sample photodiode (I).

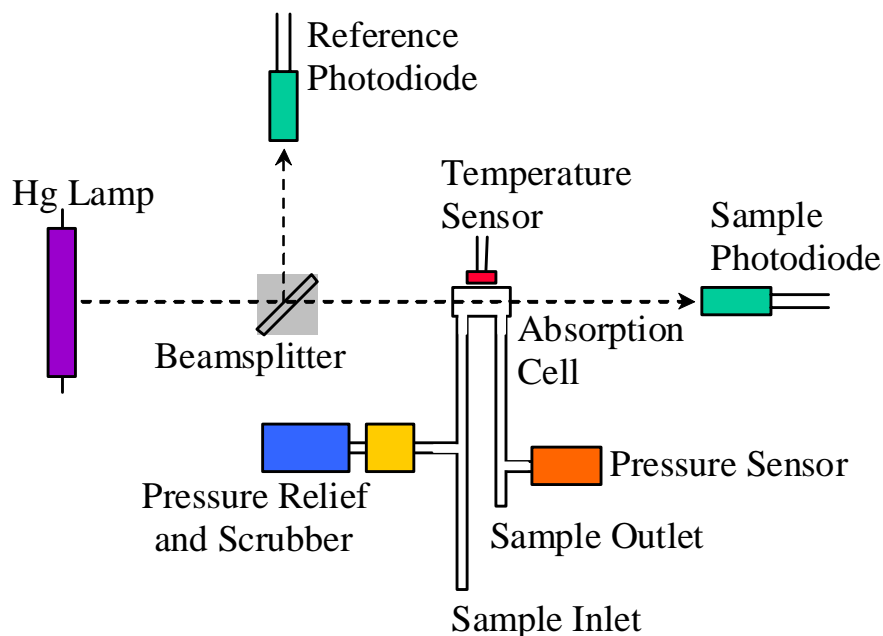

Figure 1. Schematic Diagram of the Ozone Monitor.

Ozone concentration is calculated from the measurements of I_o and I according to the Beer-Lambert Law:

$$C_{O_3} = \frac{1}{\sigma l} \ln\left(\frac{I_o}{I}\right)$$

where l is the path length (0.1 cm) and σ is the absorption cross section for ozone at 254 nm ($1.15 \times 10^{-17} \text{ cm}^2 \text{ molecule}^{-1}$ or $308 \text{ atm}^{-1} \text{ cm}^{-1}$), which is known with an accuracy of approximately 1%. The 2B Technologies instrument uses the same absorption cross section (extinction coefficient) as used in other commercial instruments.

When there is no ozone in the cell, a difference in light intensity at the reference and sample photodiodes can be expected, and it will cause a zero offset in the readings. This light intensity difference is inherent in the instrument due to the different properties of the two photodiodes, drift in the angle of the beamsplitter, contamination in the cell and thermal drift in any of the optical components. The zero drift has been determined to be less than or equal to 2% of full scale per month, non-cumulative and can easily be corrected for by using the zero function described below. The zero drift does not affect the slope calibration factor in any way, and the instrument does not need to be recalibrated after performing the zeroing function.

The pressure and temperature within the absorption cell are measured so that the ozone concentration can be expressed as a mixing ratio in percent by volume (vol%). The fraction of the sample that is ozone can then be calculated and used to determine the ozone concentration in percent by weight in either air (Wt.% air) or oxygen (Wt.% O₂). The instrument displays and records the cell temperature and pressure in addition to the ozone concentration. The cell pressure is displayed and logged in units of mbar, torr or psia and the cell temperature in units of either °C or K.

In principle, the measurement of ozone by UV absorption requires only a zero calibration to account for the different light intensities at the reference and sample photodiodes. However, non-linearity of the photodiode response and electronics can result in a small measurement error. Therefore, each instrument is compared with a reference ozone monitor calibrated to the International Ozone Association (IOA) buffered KI method. These results are used to calibrate the Ozone Monitor with respect to a slope (gain). The correction for slope is recorded in the instrument Birth Certificate. The slope parameter is entered into the microprocessor prior to shipment. The user may change the slope parameter from the front panel if desired. It is recommended that the instrument be recalibrated at least once every year and preferably more frequently. The zero may drift due to temperature change or chemical contamination of the absorption cell. As discussed below, an accurate zero correction can be measured from time to time using zero gas.

OZONE MONITOR SPECIFICATIONS

Power Requirements 11-28 V DC, nominally 440 mA at 12 V, 5.3 watt

Dimensions (with case)..... 3.75" x 8.5" x 8.5" (9.5 x 21.6 x 21.6 cm)

Dimensions (OEM version)..... 2.5" x 7" x 9" (6.4 x 17.8 x 22.9 cm)

Weight (with case) 4.5 lb (2.0 kg)

Weight (OEM version) 3.0 lb (1.4 kg)

Precision greater of 0.01 Wt.% O₂ or 1% of measurement

Accuracy..... greater of 0.02 Wt.% O₂ or 2% of measurement

Zero Drift..... 1% of full scale/month, non-cumulative

2. OPERATION

Please read all the following information before attempting to install the Ozone Monitor. For assistance, please call 2B Technologies at (303)273-0559.

NOTE:

Save the shipping carton and packing materials that came with the Ozone Monitor. If the Ozone Monitor must be returned to the factory, pack it in the original carton. Any repairs as a result of damage incurred during shipping will be charged.

Shipping Box Contents

Open the shipping box and verify that it contains the following:

1. Ozone monitor
2. 100-240 V AC power adapter
3. Serial port cable
4. USB cable
5. Relay screw connector
6. CD with Operation Manual, 2B Display Software and USB Driver
7. Ozone Monitor birth certificate (inside binder)
8. Quality control data sheet and graph (inside binder)

If anything is missing or obviously damaged, contact 2B Technologies immediately.

Operation of the Ozone Monitor

To operate the Ozone Monitor, connect it to an external power source and power the instrument by switching the power switch on. The instrument requires a 12 V DC source, which can be in the range 11-28 V DC without any detrimental effects on the measurement.

Once turned on, the instrument will display the version number of the software installed on the microprocessor. After a few seconds, the instrument will start displaying readings for ozone. The first dozen readings (requiring about two minutes) will be spurious, with large positive and negative swings due to the rapid warmup of the lamp and electronics. Also, ozone readings may be

inaccurate during the first 20-30 minutes required for the lamp, photodiodes, and internal temperature of the absorption cell to stabilize.

Inlet tubing may be attached to the ¼ inch stainless steel Swagelok fitting on the back of the instrument. The inlet tubing should be made of PTFE (Teflon[®]), PFA, FEP, PVDF or some other inert material that does not destroy ozone and that does not desorb plasticizers and other organics that can contaminate the flow path. The length of tubing should be kept as short as possible (preferably not more than a few feet) to minimize ozone destruction within the inlet tubing. Tygon[®] and polypropylene (which may look like Teflon) should not be used.

The Ozone Monitor has an internal pressure relief device that protects the instrument from excessive pressure. The device vents through an ozone scrubber when the inlet pressure exceeds 50 psi and is not meant to be used in normal operation. Although the ozone scrubber is made with an ozone destroying catalyst that has very high ozone capacity, it may not scrub 100% of the ozone if the flow exceeds several liters per minute. Operators of the instrument should not rely on the pressure relief device as a pressure regulating device or expose the instrument to pressures above 50 psi.

Measurement of the Zero Offset

If the instrument has not been used recently, check the zero measurement before use. The zero offset of the instrument can be measured by first purging the instrument with zero gas at a minimum flow rate of 0.2 L/min for at least 2 minutes. For an accurate measurement, the instrument must have been turned on long enough for the internal temperature to stabilize. The observed offset can be corrected for by running the zeroing function, as described below.

Collecting Data over the Serial Port in Real Time

To transmit data to a computer over the serial port in real time, connect the Ozone Monitor to the serial port of the computer using the 9-pin cable provided. Note that this is a “straight-through” female-female serial cable. A “cross-over” cable will not work. Start your data acquisition software, preferably using the 2B Technologies Display and Graphing Software (free download from <http://twobtech.com/software.htm>). Other terminal emulation software such as HyperTerminal (a program provided with Windows) or [Tera Term Pro](#) may be used as well.

The ozone concentration, internal cell temperature, cell pressure, reference photodiode voltage (volts), sample photodiode voltage (volts), time and date are sent as comma-delimited ASCII text to the serial and USB ports (2400, 4800 or 19200 baud as selected in menu; 8 bits; no parity; 1 stop bit) every two seconds, ten seconds, 1 minute, 5 minutes, or 1 hour, depending on the averaging time selected from the microprocessor menu. Time is provided in 24-hour (military) format, and the date is given in European style (day/month/year).

A typical data line would read:

1.03,31.7,835.9,1.28888,0.99086,01/03/10,08:40:55

where:

Ozone = 1.03 Wt.% O₂

Cell temperature = 31.7 °C

Cell pressure = 835.9 mbar (1 atm = 1013 mbar)

Reference Photodiode voltage = 1.28888 volts

Sample Signal = 0.99086 volts

Date = January 3, 2010

Time = 8:40:55 am

If outputting logged data, the output serial data line will be preceded by the log number; e.g.,

2893, 1.03,31.7,835.9,1.28888,0.99086,01/03/10,08:40:55

where 2893 is the log number.

In addition to data lines, messages are written to the serial port when logging is begun or ended, when transmission of data from the logger is begun and ended, when data collection is interrupted (e.g., due to a power failure) and when the averaging time is changed.

Menu

The following diagram summarizes the complete instrument Menu.

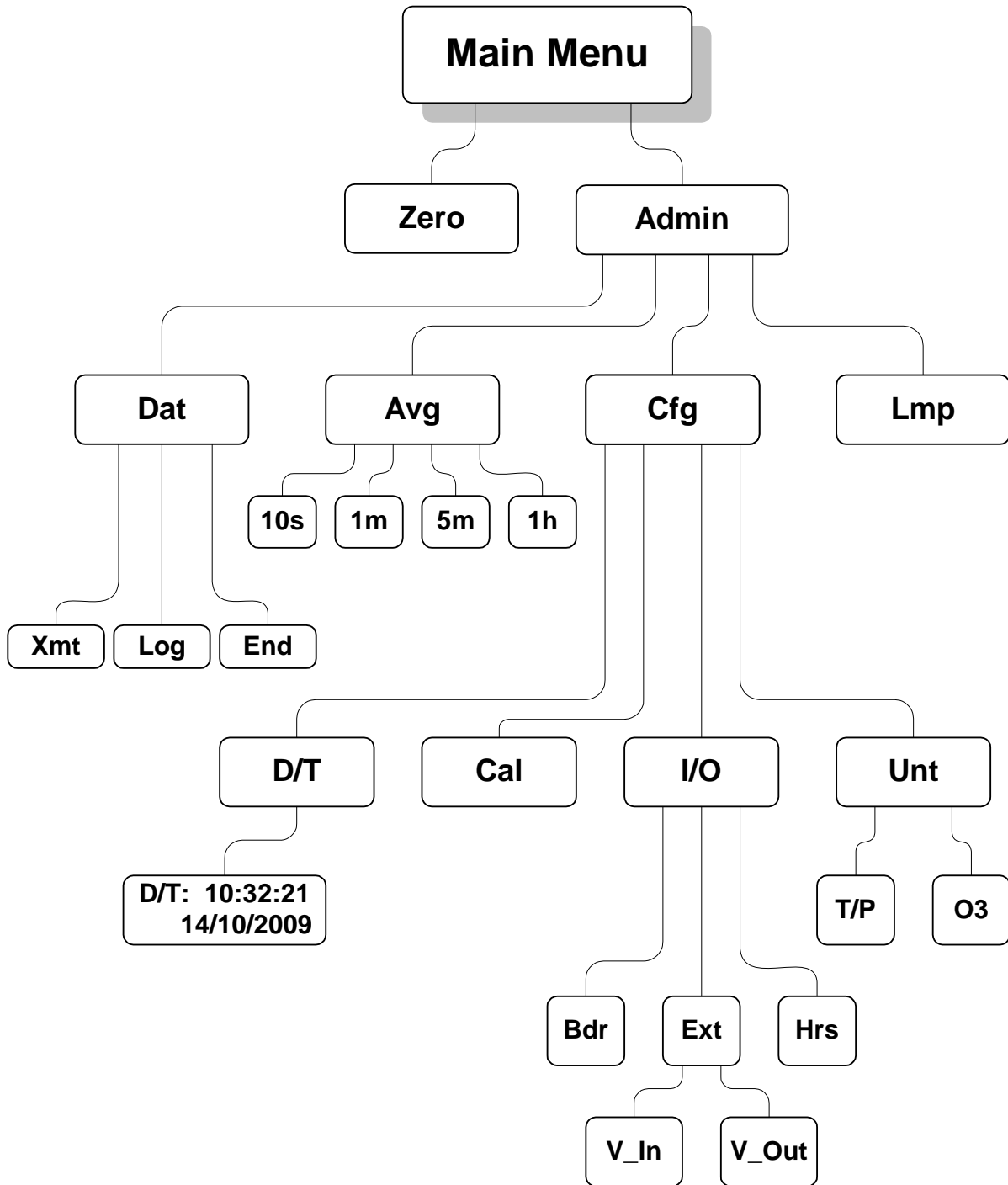

Figure 2. Instrument Menu.

Data Averaging and Data Logging Using the Menu

When first turned on, the instrument will start making measurements at a rate of once every 10 s. Data may be logged in the internal data logger. Up to 32,736 data lines containing log number, ozone concentration, internal temperature, internal pressure, reference photodiode voltage, sample photodiode voltage, time and date may be stored in internal memory, corresponding to an operational time of 3.8 days. Averaging times of 2 s, 1 min, 5 min and 1 hr also may be selected from the menu, thereby allowing the instrument to operate for 18.2 hours, 22.7 days, 113 days and 3.7 years, respectively, before filling the memory.

Selecting the Menu

The menu is accessed using the Select button on the front panel of the instrument. To reach the menu, hold in the Select button until

Menu

is displayed, then release the Select button. After a few seconds the menu will appear:

Menu
Zero Admin ←

where **Zero** and **Admin** are submenus that may be selected. A blinking cursor will show across the **Z** of the **Zero** submenu. The Select button may be rotated clockwise or counterclockwise to move the cursor under the first letter of another submenu. To select a particular submenu, move the cursor under the first letter of a submenu and momentarily press (“click”) the Select button. To exit the Main Menu and begin making measurements again, select and click on the left arrow (←).

To Auto-Zero the Instrument

Select and click on **Zero** to display:

Providing Zero
Air? Yes Cancel

Before continuing, purge the instrument with zero gas at a minimum flow rate of 0.2 L/min for at least 2 minutes and then select **Yes**. For an accurate

measurement, the instrument must have been turned on long enough for the internal temperature to stabilize. You will then see the status message:

Zeroing...

When the zeroing function is complete, you will see the status message:

**Zeroing...
Found New Zero**

The Ozone Monitor will then exit the **Menu** and return to measuring ozone.

To Log Data

Select and click on **Admin**, and then on **Dat** using the Select button. The display will now show:

**Dat Menu
Xmt Log End ←**

To start logging data, rotate the Select switch to move the cursor to **Log** and click to select the logging mode. You will then receive the prompt:

**Overwrite Data?
No Yes ←**

Warning: If you start logging, all data previously stored in the logger will be irretrievably lost. If you have data in the logger that you want to keep, be sure to download it (see below) before starting logging. Click on **Yes** if you are sure you want to start logging new data. This will return you to the **Dat Menu**. Click on ← to return to the main **Menu**, and click on ← again to exit the Menu and start making measurements. Note that “←” always takes you up one level in the menu.

The Ozone Monitor will then alternate every 5 seconds between displaying the most recent 10-s measurement and the current average value. For example, the display might read

**O3= 0.50 Wt.% O₂
T=33.3 P=989.7**

where the current 10-s measurement is 0.50 Wt.% O₂, the temperature is 33.3 °C and the pressure is 989.7 mbar. If 10-second averaging (no averaging) has been selected, five seconds later, this display might be followed by

O3= 0.50 Wt.% O₂
19:55 05/02/2010

showing that the time of the measurement is 7:55 pm and the date is 2 May 2010. If averaging has been selected, the above display will be replaced by

Avg O3= 0.55 Wt.% O₂
19:55 05/02/2010

for example, where the most recent average value of ozone computed is 0.55 Wt.% O₂. If data are being logged, the log number and number of new measurements made for the next average (minus 1) are displayed in place of the data and time; e.g.,

Avg O3= 0.12 Wt.% O₂
Log= 193:4

where **Avg O3** is the average ozone value most recently written to the logger, and the current log number is 193. The “4” in 193:4 refers to the number of 10-s data points that have been measured so far for inclusion in the next average to be displayed and logged. If 1-min averaging is used, this number will increment from 0 to 5; for 5-min averaging, the number will increment from 0 to 29; and for 1-hr averaging, it will increment from 0 to 359. This number is displayed so that the user will know how many more 10-s measurements need to be made before a new average is displayed and logged.

If there is a power failure while the instrument is in the logging mode, logging will resume after power is restored. A note of “Data Interruption” will be written to the logger prior to writing the first new data line. The instrument can accommodate multiple data interruptions due to power failures. For example, one can purposely switch the instrument off, move to another location and restart logging simply by turning the instrument back on. Data sets will be separated by the data interrupt message.

To Stop Logging Data

Hold in the Select button to obtain the **Menu**. Go to the **Dat** submenu by clicking on **Dat**. Choose and click on the **End** function. This will end data logging. You may now return to the **Dat** menu to transmit the data to a computer by clicking on **Xmt** (see below). The stored data will reside in memory (even when new measurements are being made) and can be transmitted using the **Xmt** function as often as you like. However, all stored data are lost once logging is started again using the **Log** function. Thus, you should always transmit your data to a computer before restarting logging.

If you fail to **End** logging prior to transmitting the data using the **Xmt** function, the instrument will automatically execute the **End** function for you prior to transmitting the data.

To Average Data

Hold down the Select button to obtain the **Menu**. Select and click on **Admin**, and then on **Avg** to enter the **Avg** menu:

Avg Menu
2s 10s 1m 5m 1h ←

Use single clicks to move the cursor to **2s**, **10s**, **1m**, **5m** or **1h** for averaging times of 2 s, 10 s, 1 min, 5 min or 1 hr averaging, respectively. Then click on the averaging time you want to use. You will be returned to the main **Menu**. To exit the Main Menu and start acquiring data, click on ← again.

While in averaging mode, the current 10-s measurement is displayed alternately with the average value at 5-s intervals, as discussed above. Averaged data may be logged, thereby greatly extending the length of time that the data logger can be used.

To Transmit Logged Data to a Computer Using the USB or Serial Port

Connect the USB or serial port of the instrument to your computer using the appropriate cable. Enable a data acquisition program on the computer such as the 2B Technologies Display and Graphing Software, which can be downloaded at:

<http://twobtech.com/software.htm>

Alternatively, HyperTerminal can be used (available on most Windows[®] platforms, usually in Start/All Programs/Accessories/Communications/Hyper Terminal) or Terra Term Pro, which can be downloaded at:

<http://hp.vector.co.jp/authors/VA002416/teraterm.html>

As mentioned earlier, the disadvantage of HyperTerminal is that it has a 500 line buffer limitation, but this limitation can be circumvented by logging the data to a file as it is transmitted from the Ozone Monitor. The correct settings for receiving data are: chosen baud rate (2400, 4800 or 19200); 8 bits; no parity; 1 stop bit.

Click the **Select** button to obtain the **Main Menu**. Go to the **Dat** submenu by clicking on **Dat**. Next, click on **Xmt**. The message “Logged Data” will be written to the serial port, followed by a carriage return and all of the lines of logged data. After all data are transmitted, the message “End of Logged Data” and a carriage return are written. After transmission is complete, you can return to any position in the menu or resume ozone measurements. The logged data continues to be available for transmission until a new data log is started.

To Change the Calibration Parameters

The instrument is calibrated at the factory where a slope parameter is entered into the instrument’s memory. This preset calibration parameter is given in the instrument’s Birth Certificate and recorded on the calibration sticker on the back of the instrument. However, the calibration parameters may be changed by the user. For example, it may be desirable to provide a positive offset by a known amount (e.g., 0.10 Wt.% O₂) if the analog output is being used for external data logging since the analog voltage output does not go negative below zero Wt.% O₂, and the current output does not go below 4 mA. Because of noise and/or an inherent offset, some measured values will be below zero at very low ozone concentrations or while zeroing the instrument with zero gas. Also, the instrument zero may drift by a few hundredths of 1 Wt.% O₂ over time. For this reason, zeroing of the instrument using zero gas to determine the offset is recommended. Any change in the slope (gain) of the instrument is likely due to a serious problem such as contamination, but it also can be adjusted. Once the zero of the instrument is corrected, the slope may be adjusted so that the instrument readout agrees with the readout from another instrument whose calibration is considered to be accurate.

To change the calibration parameters, choose the **Cfg** submenu from the main **Menu** and click on **Cal** to obtain the display

Cal Menu
Z= 0.03 S= 1.012

Here Z is an applied offset (in this case 0.03 Wt.% O₂) and S is the slope applied (in this case 1.012). The value of Z will be 0.00 if you have performed the auto-zeroing procedure described above. You can provide an offset, however, by changing the value of Z here. When reporting ozone, the value of S is multiplied by the measured ozone value and then the value of Z is added. During calibration, the instrument is first auto-zeroed and checked to make sure that a reading of zero is obtained with sampling air or oxygen containing no ozone. The value of S is set to 1.000 and ozone having a know concentration

is measured. If, for example, the instrument consistently reads 2.5% low, the value of **S** is then set to 1.025. If an offset is desired (e.g., when using an analog output to record the data), the value of **Z** may then be adjusted to the value of the desired offset.

When the **Cal Menu** first appears, the **Z** will be underlined with a cursor. You may rotate the Select switch to choose the calibration parameter **S** or **Z**. A single click on **S** or **Z** will select that parameter for change and activate a blinking cursor. Once **S** or **Z** is selected, its value can be changed by rotating the Select switch to the left or right. After choosing the desired value, a click turns off the blinking cursor and allows you to scroll to the other parameter or to ← to exit the submenu. Once the values of **Z** and **S** are set, clicking on ← will return the display to the **Cal** menu, another click on ← to the **Cfg** menu, and another click on ← will return to the **Main Menu**. The calibration parameters reside in non-volatile memory and are not affected by power failures.

To Set the Time and Date

From the **Main Menu**, select the **Cfg** submenu. Next, select the **D/T** submenu. The display will read, for example:

D/T: 14:32:21 ←
17/10/2009

meaning that it is 21 seconds after 2:32 p.m. on October 17, 2009 (military time and European date). To change a number in the date and time, rotate the Select switch to underline the numeral you want to change. A single click then causes a blinking cursor to cover that numeral. The number can then be changed by rotating the Select switch. Once the number is correct, click on the Select switch to turn off the blinking cursor. You may now rotate the Select switch to choose another numeral to change. Once the time and date is correct, clicking on ← will set the internal clock to that time and return the display to the **Cfg** menu. As in setting a digital watch, the seconds should be set in advance of the real time since the clock starts to run again only when the set time is entered; in this case by clicking on ←.

Accessing the Serial Menu

Instrument parameters and logging tasks can be accessed via the serial port or the USB using a terminal emulator such as Tera Term Pro or HyperTerminal running on an attached computer. Commands can be sent using the terminal emulator set with the properties listed in the section of this manual “Collecting

Data over the Serial Port in Real Time". Listed below are the lower case letters that are commands for performing certain operations while the instrument continues to measure:

- l** Start logging and write over existing logged data
- t** Transmit logged data
- e** End logging
- h** Output serial data line header
- m** Serial menu

If the letter **m** is sent as a command, **menu>** will be displayed in the terminal emulator window. When the serial menu is accessed, the instrument is no longer making measurements; it is waiting for the next command to be entered. The following is the list of menu items accessible from this point:

- l** Start logging and write over existing logged data
- t** Transmit logged data
- e** End logging
- h** Output serial data line header
- a** Displays list of possible averaging times and the number that must be entered to change to the desired averaging time
- z** Displays current zero calibration setting and waits for new setting followed by a carriage return
- s** Displays current slope calibration setting and waits for new setting followed by a carriage return
- c** Clock menu, displays current date and time and waits for **d** or **t** to be entered
 - From clock menu,
 - d** Asks to enter date in DDMMYY format
 - t** Asks to enter time in HHMMSS format
- x** Exit menu and return to measuring

Collecting Data from the Analog Output

The data may be logged in real time using a data logger attached to the D9 connector on the back panel of the instrument using either a voltage or current recorder or data logger. The 0-2.5 V output is measured across pins #1 (+) and #5 (ground). The 4-20 mA current output is measured across pins #9 (+) and #5 (ground). Looking at the back of the instrument, the pin numbers for the connector are:

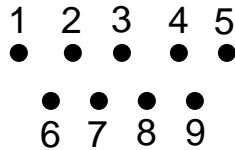

To change the analog output voltage scaling factor, go to **Menu/Cfg/I/O/Ext.** The display will briefly read “VOUT Menu” followed by

2.5V=01.00 Wt.% O₂
20mA=01.00 Wt.% O₂ ←

In this example, the output scaling factor is set as 2.5 Volt (full scale) = 1.00 Wt.% O₂; i.e. 1 Volt = 0.40 Wt.% O₂. Also, the current output will be scaled such that the full scale of 20 mA corresponds to 1.00 Wt.% O₂. A reading of zero ozone concentration will be output as 0 V and as 4 mA. You can use the select switch to change the scaling factor to the value of your choice by selecting and changing the individual digits in the scaling factor of either the voltage or current. Thus, the instrument is not limited to a fixed number of “ranges” common to most ozone monitors. Instead, any range can be defined.

To Set the Relay Limits

The Ozone Monitor may be used to control other devices such as ozone generators using a 12 amp relay. To set the On and Off limits of the relay, choose **REL** from the **Ext** submenu. The menu will show, for example:

On =04.90 Wt.% O₂
Off=05.10 ←

With these settings the relay will close (pass current) until the ozone concentration exceeds 5.10 Wt.% O₂. Above this concentration the switch relay will open. The relay will not close again until the ozone concentration drops below 4.90 Wt.% O₂. In this way, for example, ozone concentration from an ozone generation could be controlled in the range 4.90 to 5.10 Wt.% O₂. You may now move the cursor using the Select switch to choose the digits in the On and Off relay settings, choose a digit to change by depressing the Select switch, and rotate the Select switch to change those settings. To choose another digit to change, depress the Select switch again to remove the blinking cursor.

Physical connection to the relay is made by means of a supplied screw connector for attaching wires to your device. The center terminal is common. When viewing the connector from the rear of the instrument, the terminal on the

right is in normally open (i.e., it closes when the ozone concentration is below the first setpoint). This is the connection you would ordinarily use. The screw connector on the left is normally closed; i.e., it behaves in the opposite manner as the right screw terminal.

To Change the Baud Rate

The baud rate for transmission of data to a computer over the USB or serial port may be changed by going to **Menu/Admin/Cfg/I/O/Bdr** to obtain:

Baud Menu
2400 4800 19200 ←

Choosing a baud rate will automatically return you to the **I/O** submenu.

To Read the Number of Hours of Ozone Monitor Use

The instrument keeps track of the total number of hours of use. This is helpful for determining when the instrument should be serviced, a pump replaced, etc. To read the number of hours of operation choose **Menu/Admin/Cfg/I/O/Hrs**.

To Change the Ozone, Temperature and Pressure Measurement Units

From the **Cfg** submenu, choose the **Unt** submenu:

Unt Menu
T/P O3 ←

Select **O3** from the **Unt** submenu to change the units reported for ozone concentration:

O3 Units Menu
Wt%O2 Wt%air g/Nm3 g/m3 Vol% ←

You may now select units of percent by weight in oxygen (**Wt%O2**), percent by weight in air (**Wt%air**), grams per normalized cubic meter (**g/Nm3**, normalized to 1 atm. and 0 °C), grams per cubic meter (**g/m3**) or percent by volume (**Vol%**).

Select **T/P** from the **Unt** submenu to change the units reported for temperature and pressure:

T/P Units Menu

T:C P:mbar ←

You may now select units of °C or K for temperature and mbar, torr or psia for pressure using the same procedure used to set the units for ozone concentration.

Lamp Test

If the instrument always reads near zero in the presence of ozone or if the **Low Lamp** light is turned on, it is useful to perform the lamp test to make sure that the lamp is turning on. Before performing the lamp test, allow the instrument to warm up for at least twenty minutes.

Choose **Lmp** from the main **Menu**. The display will momentarily read “**Lamp Test**”. The photodiode voltages will then be displayed, for example:

Smp=1.24578 V
Ref=1.50364 V ←

The photodiode voltages (PDV) are a measure of the lamp intensity and should be in the range 0.6-2.2 volts. Since absorbance is a ratio measurement, the absolute value of the voltages is not particularly important. However, above 2.5 volts, which could occur if the instrument is allowed to become too hot, the photodiode is saturated and the calculated ozone concentration will be zero. Photodiode voltages less than 0.6 volts without any ozone in the cell are indicative of either a weak lamp or a dirty detection cell and may result in a noisy measurement. Photodiode voltages will typically increase as the instrument warms up. Lamp drift is continuously monitored and corrected for in the firmware and thus has very little effect on the measured ozone concentration. If your lamp fails the lamp test during the first year of operation, contact us for a new lamp under the instrument warranty.

3. MAINTENANCE/TROUBLESHOOTING

The Ozone Monitor is designed to be maintenance-free. The only component with a limited lifetime is the lamp, which has a lifetime of ~20,000 hours. It is recommended that the instrument be returned to 2B Technologies if any component fails. Alternatively, the user may install components at their own risk. In that case, please contact 2B Technologies for instructions.

The 106-H has four status LEDs on the front plate to indicate any system issues that may require troubleshooting:

Cell Dirty: Indicates that the ratio of the sample photodiode voltage to the reference photodiode voltage is less than 0.5. This status light can only be activated during the zeroing function when the cell is purged with zero gas. The normal state is OFF.

Low Flow: This function is not yet operational. In a future revision, the LED will indicate when there is insufficient flow through the instrument. The normal state is OFF.

Low Lamp: Indicates that the lamp intensity, measured by the reference photodiode, is below 0.6 volts. The normal state is OFF.

Power On: Indicates that there is power to the instrument and that the main circuit board is working properly. The normal state is ON.

The following are indications of various instrument malfunctions.

Table I. *Troubleshooting the Ozone Monitor for performance problems.*

Problem/symptom	Likely cause	Corrective action
<i>Instrument does not turn on (Power On LED is OFF).</i>	Power not connected properly or circuit breaker open.	Check external power connection for reverse polarity or a short and wait a few minutes for the thermal circuit breaker to reset.
<i>Lamp Low LED is ON.</i>	The lamp intensity is low.	If the reference photodiode voltage is near 0.6 volts, the instrument may still function properly, but the lamp should be replaced when possible.
<i>Cell Dirty LED is ON.</i>	Absorption cell is dirty. Poor instrument zero.	Clean the cell. Zero the instrument
<i>Display is blank or nonsense.</i>	Bad connection of display to circuit board.	Remove top cover and reconnect display to circuit board. Check solder connections to display. A new LCD may be required.
<i>Cell temperature reads low by several 10's of degrees.</i>	Absent or loose connection of temperature probe cable to circuit board.	Remove top cover and reattach connector to circuit board.
<i>Analog output is constant or does not track front display.</i>	Cable not properly connected between analog output and recording device. Wrong scaling factor selected In menu.	Check continuity of your analog cable to your recording device and make sure correct connector pins are being used. Check and reset analog output scaling factor in the Menu.

Select switch does not work.	Bad solder joint to circuit board or damaged select switch.	Remove top cover and check solder connection to select switch. It may be necessary to replace the select switch.
Serial port does not work.	Wrong serial cable used. Wrong baud rate selected.	A "straight through" serial cable is provided. Some data collection devices require a "cross over" cable in which pins 1 and 3 are exchanged between the two ends of the cable. Use a "cross over cable or additional connector that switches pins 1 and 3. Make sure that the baud rate chosen in the menu matches the baud rate setting of your data acquisition program.
Required calibration parameters are large (>±15% slope) when calibrated using a reliable ozone instrument.	Flow path is contaminated.	Clean flow path with methanol following the Cleaning Procedure.

2B Technologies offers reasonably priced customer service for instrument repairs. The calibration service includes cleaning of the entire flow path with methanol, testing of all components for proper function and calibration against an IOA-traceable standard. The best way to contact us for service is to log a customer service ticket at www.twobtech.com/techsupport. Normally, you will hear back from us by email within a few hours. Or, call us at +1(303)273-0559.

There is a great deal of technical information about our instruments posted as technical notes at www.twobtech.com/tech_notes.htm. Manuals, brochures, software, cleaning procedures and scientific papers may be downloaded at www.twobtech.com/downloads.htm.

4. CALIBRATION

Every analytical instrument is subject to some drift and variation in response, making it necessary to periodically check the calibration. Since the reliability of the data collected from any analytical instrument depends on the accuracy of the calibration, it is necessary to calibrate the instrument against a recognized standard such as the International Ozone Association (IOA) KI method. This method is detailed in the Iodometric Method for the Determination of Ozone in a Process Gas, Revised Standardized Procedure 001/96 (KI Method) established by members of the Quality Assurance committees of the International Ozone Association (IOA), including the Pan American Group (PAG), European African Group (EAG) and Nippon Islands (NIG). This procedure is an expanded version of the IOA method described in: Rakness, K., et al., Guideline for Measurement of Ozone Concentration in the Process Gas from an Ozone Generator, *Ozone Science and Engineering* **18**, 209-229 (1996). It should be noted that there is no method directly traceable to NIST for ozone concentrations above 1 ppm.

Equipment Required

For routine calibration, an instrument can be calibrated against a working ozone standard, which is an ozone monitor that has been calibrated against the IOA KI method. The equipment that is needed to carry out the calibration is commercially available. Calibration using a working ozone standard involves the generation of ozone concentrations that are simultaneously measured by the working standard and the instrument undergoing calibration. This procedure requires the following equipment:

1. Zero gas source
2. Ozone generator
3. Sampling manifold (inert material such as PTFE or FEP only)
4. Sampling lines (inert materials such as PTFE or FEP only)
5. Ozone monitor calibrated against the IOA KI Method

CALIBRATION PROCEDURE

A multipoint calibration should be performed within the calibration frequency, any time major disassembly of components is performed, or any time the span checks give results outside of the acceptable limits.

Instrument Preparation

1. Turn on the Model 106-H Ozone Monitor and allow it to stabilize for a minimum of one hour.
2. Allow the working standard to warm up according to the instrument user manual.
3. Enter the calibration menu (Main Menu\Admin\Cfg\Cal\O3) and set the zero (Z) value to 0.00 and the slope (S) value to 1.000.
4. Connect the ozone monitor to the manifold on the ozone calibration setup.

Measurement of Zero Gas

1. Verify that the zero gas supply is on and the ozone generator is off. The same zero gas supply used in the ozone generator must be used in the ozone generator.
2. Allow the Model 106-H to sample zero gas until the response is stable.
3. Perform the zero function in the menu.

Measurement of Ozone Standards

1. Generate an ozone concentration slightly less than the concentration range of interest and allow the ozone generator to warm up for at least 5 minutes. The same zero gas supply used for making zero gas measurements must be used in the ozone generator.
2. Allow the Model 106-H Ozone Monitor to sample the ozone concentration standard until a stable response is measured.
3. Record the average response of the ozone monitor as well as the average response of the working standard.
4. Generate several other ozone concentration standards. At least 5 ozone concentration standards are recommended over the range of interest.
5. For each ozone concentration standard, record the response of the ozone monitor as well as the working standard.

Calibration Curve

1. Plot the Model 106-H Monitor responses (x-axis) versus the corresponding standard ozone concentrations (y-axis).
2. Fit the data to a straight line ($y = mx + b$) using the linear regression technique to determine the calibration relationships.
3. Determine if any points deviate significantly from the line, which is an indication of an error in determining the calibration curve. The error may be due to the calibration setup or the ozone monitor being calibrated.
4. The slope of the line is the gain factor (S) that needs to be applied to the ozone monitor response to calibrate it to the working standard. If

the slope is outside of the range from 0.950 to 1.150, this is an indication of a problem in the calibration setup or the ozone monitor being calibrated.

5. Enter the calibration menu (Main Menu\Admin\Cfg\Cal\O3) in the instrument software and set the slope calibration parameter.

PERIODIC SPAN CHECKS

To ensure the quality of the ozone monitor data, periodic zero and span checks can be performed by following the steps below:

1. A span check is performed by sampling an ozone concentration at the high end of the concentration range of interest following the "Measurement of Ozone Standards" section above.
2. Average measurements from the zero check or span check should be within the instrument specifications. If the measurements are not within specifications, this is an indication of problem in the calibration setup or the ozone monitor being checked.

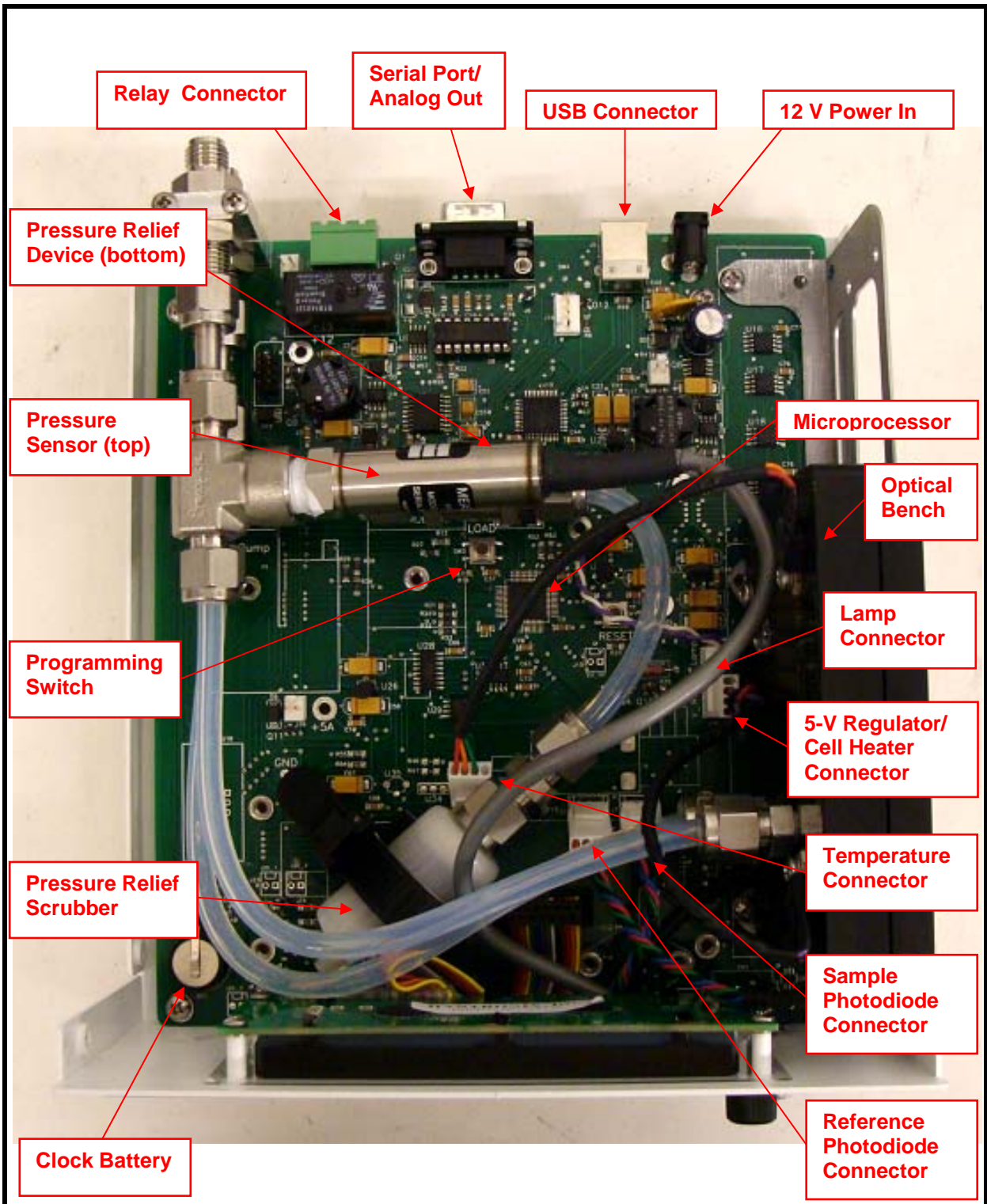

Figure 3. Standard Version of the Model 106-H.



Figure 4. Front Plate of the Model 106-H.

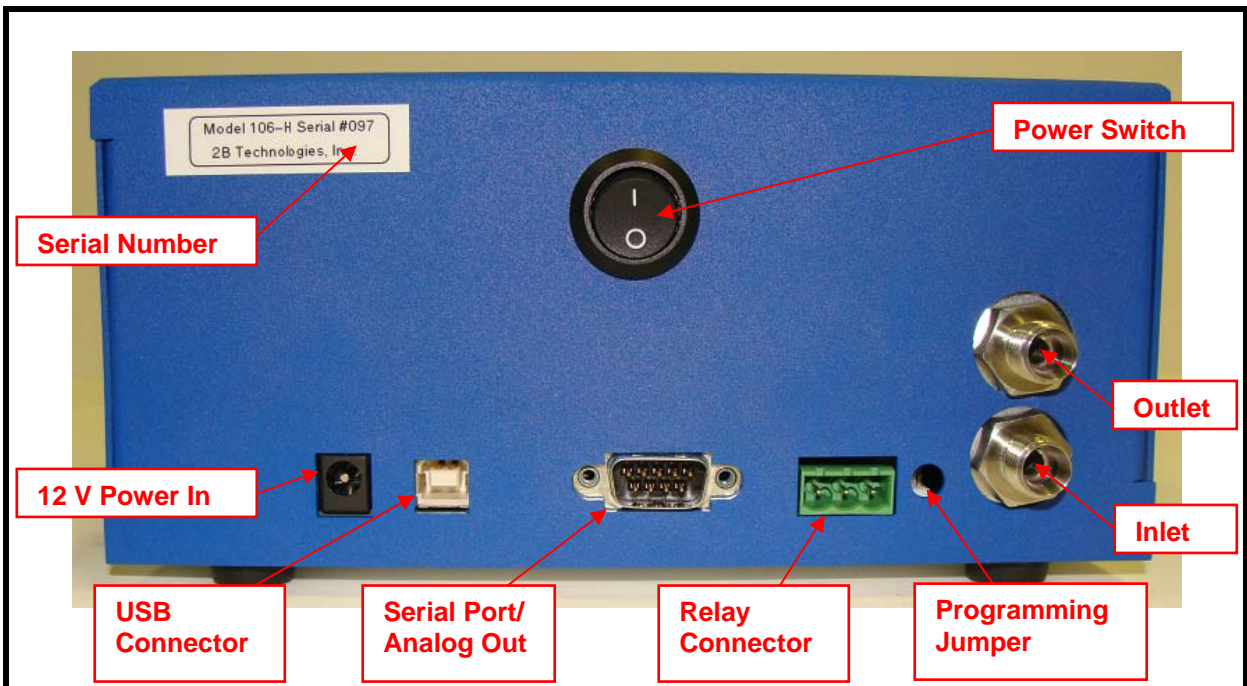

Figure 5. Back Panel of the Model 106-H.

5. PARTS LIST

The following list includes those parts that are user serviceable.

Part Number	Description
OZLAMP106	Lamp and inverter
OZDSP106	LCD display and cable
PDASSY106	Photodiode assembly and cable
RELCON	Relay connector
SERCABL	Serial port cable (to computer)
USBCABL	USB Cable
TEFTYG	Teflon-lined Tygon® tubing

APPENDIX A: USB INSTALLATION

The following procedure describes how to install the USB connection for the Model 106-H.

Items Required

- Model 106-H Ozone Monitor
- USB Cable
- PC Computer with Windows 2000 or XP
- USB to UART Driver Disk

Driver Installation

1. Insert USB to UART Driver Disk in the computer's CD ROM drive.
2. The installation files are located in a zip folder on the CD. Navigate to the folder labeled "cdc_NTXP" and double click on it.
3. Unzip the contents to a folder on the desktop or any area you wish.
4. With the Model 106-H off, attach USB cable from the 106-H to a USB port on the computer.
5. Turn on Model 106-H. The install wizard should pop up as follows. Select "No, not this time" and click "Next".



6. Select the “Install from a specific location” option and click “Next”.

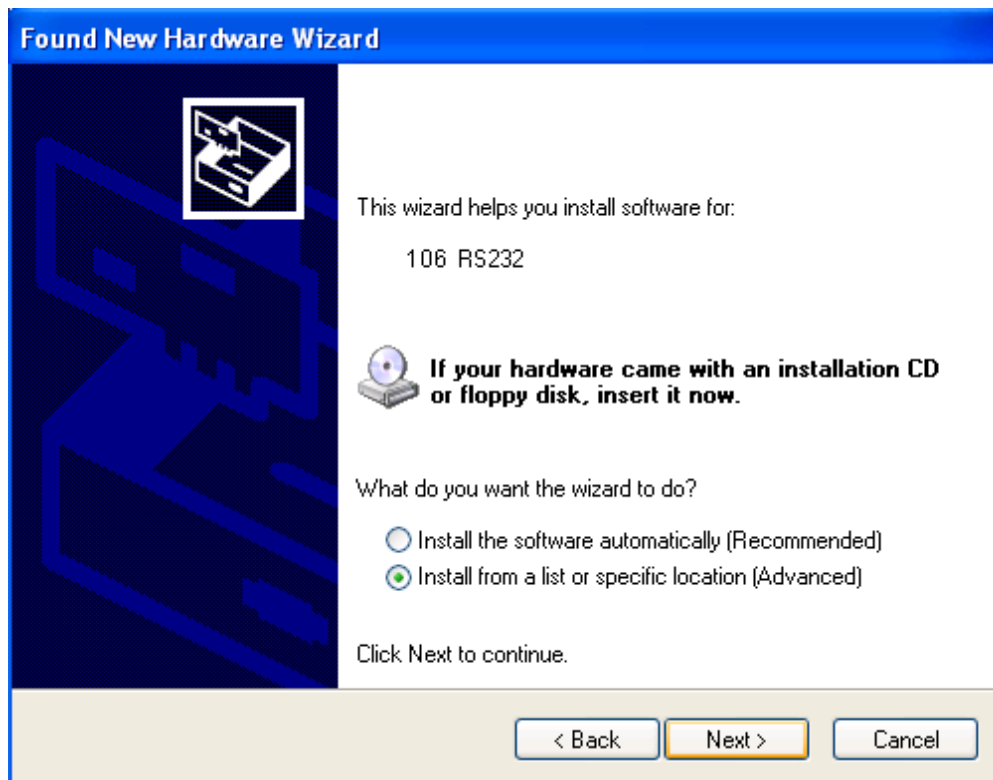

7. Navigate to folder where you unzipped the cdc_NTXP.

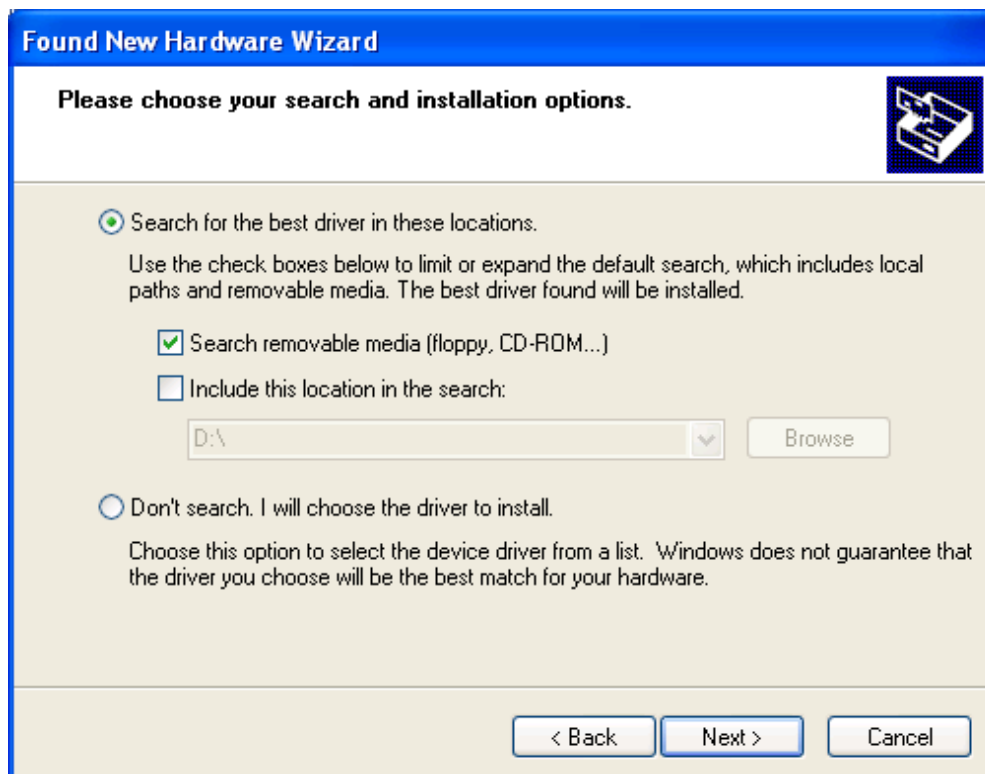

8. Select "Continue Anyway" when this window appears.



9. After a few seconds, the driver will be finished installing.



APPENDIX B: USING THE USB CONNECTION

Determine the connection port

After installation is complete, determine which COM port the connection is using. This can be done by the following procedure.

1. If using Windows (XP, Vista 7), go to the control panel and select “System”.
2. Click on the “Hardware” tab.

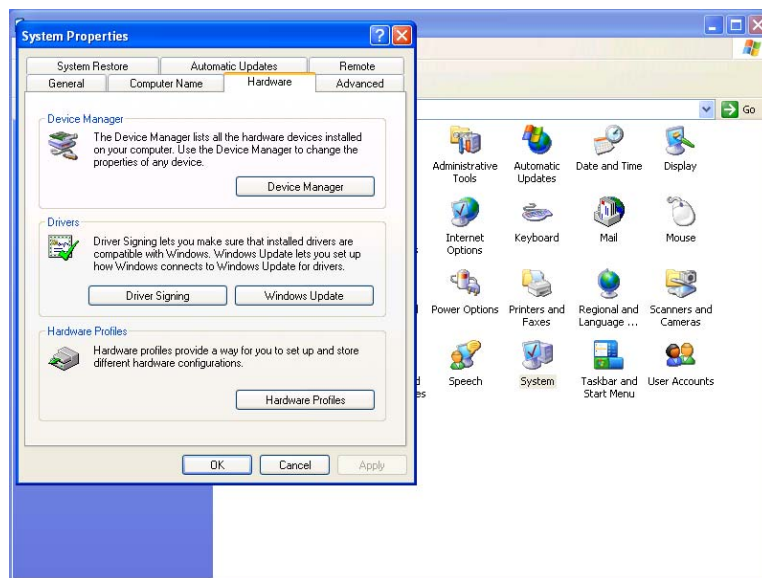

3. Click the “Device Manager” button.
4. Press the “+” sign next to “Ports”.

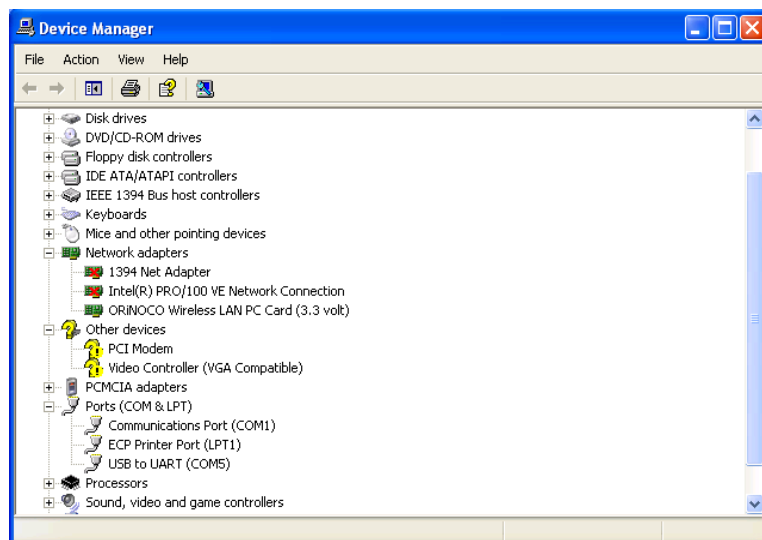

-
5. In parenthesis, next to the “USB to UART” listing is the assigned COM port number. This number will be used for the settings for the Terminal emulator or software used to read data from the Model 106-H.

Using the Connection

- Plug the USB cable in after the powering the Model 106-H to ensure correct functionality.
- When setting up your software or terminal emulator, choose the correct com port listed in the Device manager.
- Use these baud rate settings: 2400, 8 bits; no parity; 1 stop bit.
- Use 2B Technologies Display and Graphing Software (free download from <http://twobtech.com/software.htm>) to read measurement data from the Model 106.